



# An Internet of Living Things based device for a better understanding of the state of the honey bee population in the hive during the winter months

Fernando Aguirre Arribas, Miguel Romero Hortelano \*

Universidad Nacional de Educación a Distancia (UNED), Spain

## ARTICLE INFO

### Keywords:

Beehive  
Honey bees  
Digital farming  
Internet of Things  
IoT

## ABSTRACT

Monitoring beekeeping processes is a research area that is increasingly attracting interest, not only in order to maximize honey productivity but also to preserve the bee's health and its environment. This paper presents a low-cost low-invasive system that uses IoT technologies as MQ Telemetry Transport, MQTT, and Node-RED, in an open hardware platform easily reproducible and royalty-free, to capture in real-time valuable information in form of a 3D-grid to show how the bees are located within the hive during the winter months using spatial thermal data without the need to open the hive up, thereby preventing manual manipulation by the beekeeper which puts the bees welfare in jeopardy. This system can reveal unexpected or little-known bee behaviors, facilitating a more comprehensive analysis of the health and strength of a bee colony to help beekeepers make the most appropriate decisions to ensure the productivity of their hive.

## 1. Introduction

The worrisome decline of the number of pollinators, and especially the diminishing populations of honey bees, around the world, is not a new fact and yet their numbers continue to fall at an alarming rate year by year. In the EU, European institutions have already taken note of this situation (The European Parliament, 2019). The situation urgently requires finding a means to better monitor these populations during the critical winter months; this is when beekeepers run the greatest risk of losing their honeybee colonies. A large amount of international research programs rely on the information provider named Prevention of honey bee COLony LOSSes (COLOSS, 2022). This data is then used by different researchers to identify risk factors of honey bee winter mortality such as parasites, diseases or environmental conditions (Zee, Gray, & Pisa, 2015). In (Esch, et al., 2020) the authors collected data during two consecutive winters then tried to correlate the following different potential causes of mortality: *varroa* Infestation, frost days, flying hours, etc. Finally, they concluded that the interaction between their list of causes and the bee's winter mortality is complex and not yet fully understood.

Recent developments in the field of smart devices make it possible to capture, monitor and handle data from the bee's environment using wireless communications technologies and IoT. Following this line, proposals for multisensor applications for remote monitoring of a honey

bee hive can be found in the literature; without the intention of being exhaustive; we can mention the manuscripts (Cecchi et al, 2019), (Debauche, et al., 2018), (Tashakkori, Hamza, & Crawford, 2021) or (Zgank, 2020). All of them are good examples of how the IoT concept enables remote monitoring and allows beekeepers to detect abnormal behaviors within the bee colony. The system described in this study is unique in that it utilizes a larger number of sensors as well as in the specific arrangement of these sensors within the beehive. This sets it apart from other studies of a similar nature that often rely on limited data collected from only one or too few sensors placed on top of the beehive's frames. Data from multiple sensors arranged all over the hive, combined with IoT, enable a permanent transmission of valuable information regardless of the positioning of the bee cluster, insulation and other factors that could affect the quality and quantity of transferred data.

Our aim is to present the developed system, whose main goal is to obtain information about position and size of honey bee clusters using temperature readings by means of generating a heatmap. It allows both beekeepers and researchers to acquire essential spatial imagery information in real-time, which is also recorded in the system at the desired frequency. Thereby making it easier to correlate and identify possible risk factors, even test the efficiency of a possible treatment.

\* Corresponding author at: Control and Communication Systems Department, Spanish Distance Education University (UNED), C/ Juan del Rosal N.16, 28040 Madrid, Spain. Tel.: +34 913987943.

<https://doi.org/10.1016/j.compag.2023.108026>

Received 10 October 2022; Received in revised form 20 May 2023; Accepted 27 June 2023

Available online 15 July 2023

0168-1699/© 2023 The Author(s). Published by Elsevier B.V. This is an open access article under the CC BY-NC-ND license (<http://creativecommons.org/licenses/by-nc-nd/4.0/>).

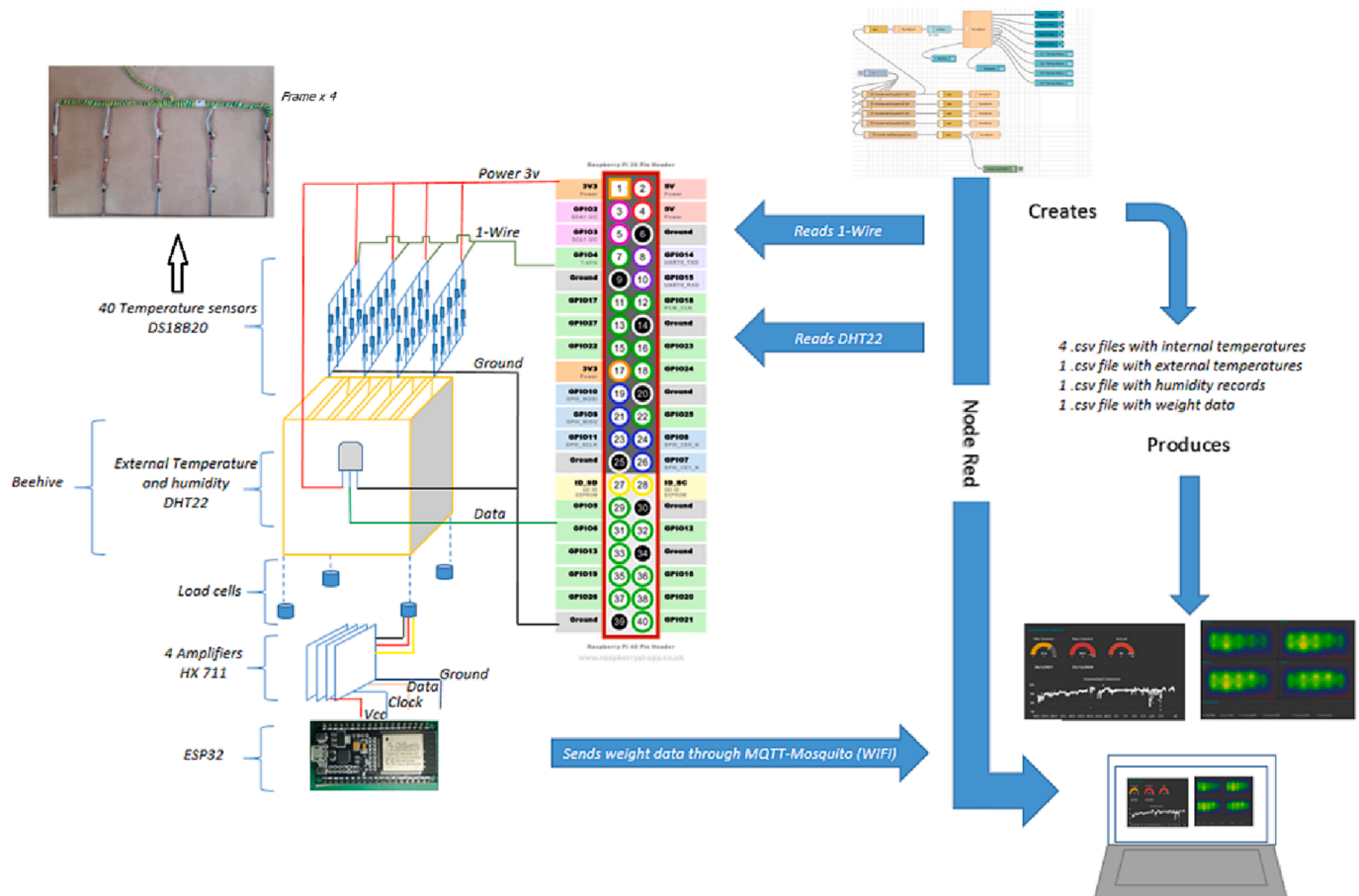

Fig. 1. Structure, installation and connections.

2. Materials and methods

Temperature measurements were collected from a beehive located in Belgium. In order to obtain a maximum amount of data, temperature sensors were arranged to ensure continuous tracking of the population inside the hive without disturbing the bees and preventing any interference in their behavior. The sensors must be introduced into the hive while preparing it for winter and must be protected, otherwise they could be damaged by the bees. Furthermore, a hive super was used to install all the connections to the microcontrollers and power. The data fetched from the hive is based on three main pillars: sensors, microcontrollers and communications in the form of an evolution of IoT concept for continuous monitoring of the biological system which is called IoT (Internet of Living Things), concept on which the proposed system relies for monitoring but safeguarding the well-being of the hive.

The complete system diagram and connections are shown in Fig. 1, which is explained as follows. The system controller is a versatile and economical SBC (Single Board Computer): the Raspberry Pi. The microcontroller ESP32 was used to receive load cells readings. For the recording of the internal hive temperature, we opted for the DS18B20 sensor, which communicates over the minimalist 1-Wire bus system, minimizing the required wiring. These sensors were welded on a metal frame. Four such frames were created thereby resulting in a three-dimensional matrix of 5 × 2 × 4, and a total of 40 sensors being used. This arrangement of the sensors has allowed us to construct a spatial heatmap (see upper left of the figure) as we will explain later. The external temperature and humidity were measured by the DHT22 sensor that can measure humidity in a range of 0–100 % and temperature between –40 to 80 °C.

We used Node-RED to assemble and represent the data by using its

browser-based editor making it easy to wire together flows and nodes. The nodes can be refined with Javascript and we consider this to be one of the most important advantages of this tool. Moreover, system security is entrusted to Node-RED which has mechanisms to prevent external intrusions.

MicroPython is the language used to program the operating logic of this system. It is an efficient implementation of the Python runtime that has been optimized for microcontrollers hardware. Communications have been carried out using MQTT which is a standard protocol for messaging on the IoT environment.

The information was read, stored and updated in different text files – a file for each frame – by a Python script. Each file had the same information structure, and date, followed by the ten temperature measurements. The data files are passed to Node-RED heatmap node in the form of an array. The system starts by transforming the text files with recorded values into csv format. Once all files are in csv format, they are saved in global variables to enable other nodes to access the contained information. Each line in the different files represents a point in time, thereby enabling the beekeeper to display the cluster evolution at one point in time within the beehive.

The external humidity and temperature are read using Node-RED’s DHT22 node with the information being stored in two different text files: one for the temperature and another for the humidity. Finally, weight data is read using HX711 amplifier and 4 load cells sensors and stored in a csv file.

3. Representation of the obtained data

The data resulting from the readings of the internal temperature sensors distributed in 4 frames, as it is depicted in Fig. 1, are stored and

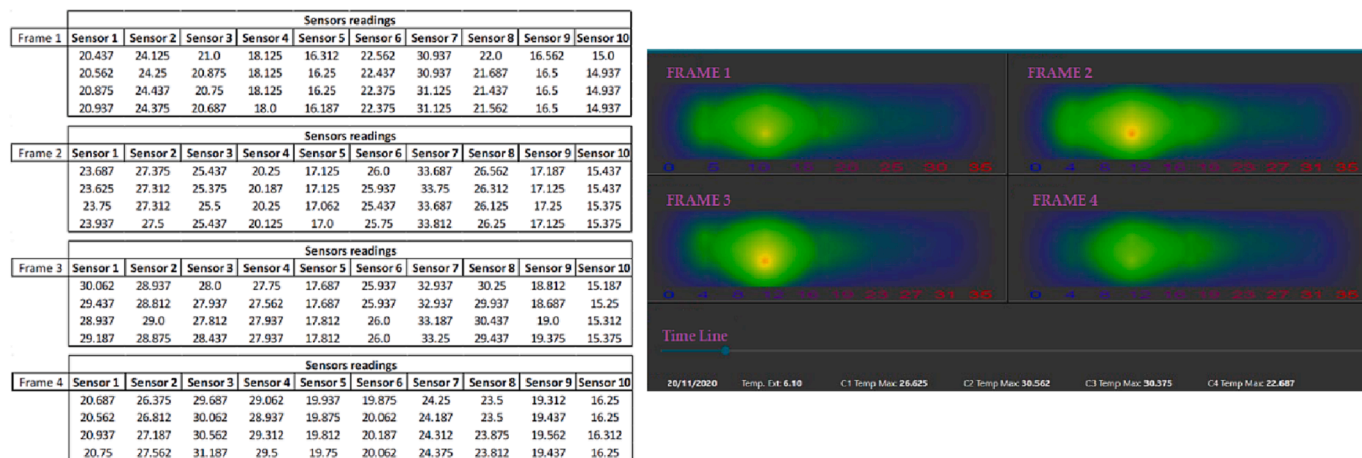

Fig. 2. Internal temperature readings and the generated heatmap.

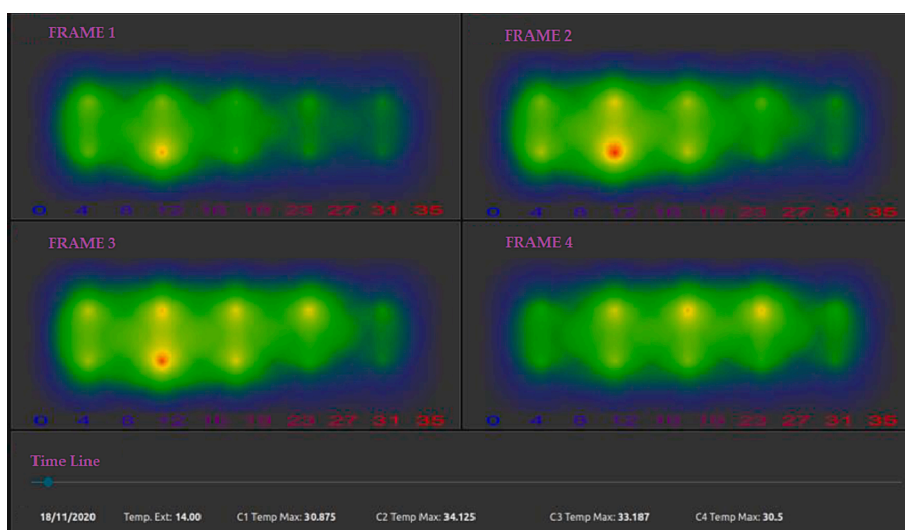

Fig. 3. Heatmap representation on 18/11.

used to generate a heatmap which represents the position of the bee cluster inside the hive. On the left side of Fig. 2, the internal temperature readings of each sensor of each frame at a given time are shown. Using this data, the system generates the heatmap shown on the right side of Fig. 2.

In each frame of this heatmap, the spatial distribution of temperature is observable. As shown in the temperature bar below the thermography for each frame, colors close to blue mean low temperatures (0 °C) and colors close to red mean high temperatures (35 °C). The time line bar allows to scroll and view all the heatmaps recorded in the system sorted by date.

Finally, the system also records the weight, temperature and humidity values outside the hive, which can be consulted through its graphical representations, highlighting the maximum, minimum and current values.

#### 4. Results and discussion

Bees exhibit distinct seasonal states (Egils & Almars, 2013). During the months when temperatures drop, they form a thermo-regulating cluster (Doke, Frazier, & M., 2015) and the behavior of any given individual bee depends on the position of other bees as well as on the overall temperature (Sumpter & Broomhead, 2000). The overwintering state of a honey bee colony is characterized by changes in the behavior

and physiology of individual bees, including reduced individual activity, changes in endocrine profiles, etc. (Doke, Frazier, & M., 2015).

It is presumed that the whole cluster moves in unison during the winter months in order to fetch the honey that has been stored in the upper parts of the frames throughout the spring and summer months.

Fig. 3 shows where the bees were positioned when the external temperature was 14 °C; in these instances, we recorded maximum internal temperatures of around 33 °C in the lower part of the frames, which in turn indicates the brood’s position.

The following spring, the studied hive was opened up and the first larva group was found exactly where the highest temperatures were read, the same place the cluster was situated during the winter months. This one and the cluster evolution position during winter lead us to the conclusion that the bees maintain the same behavioral pattern as in the summer but in a more restrained manner; during the hotter months they spread out outside seeking honey and nectar while the queen stays inside the hive, and during the colder months they emulate this ‘fetching’ activity within the beehive while the queen remains in the center of the cluster.

We also noticed an interesting reaction when the winter treatment against varroa was applied, as shown in Fig. 4, at the start, the internal temperatures (max. value) followed the same pattern as the external temperatures. This trend changed when the winter treatment against varroa – marked as a red line in the graph – was applied.

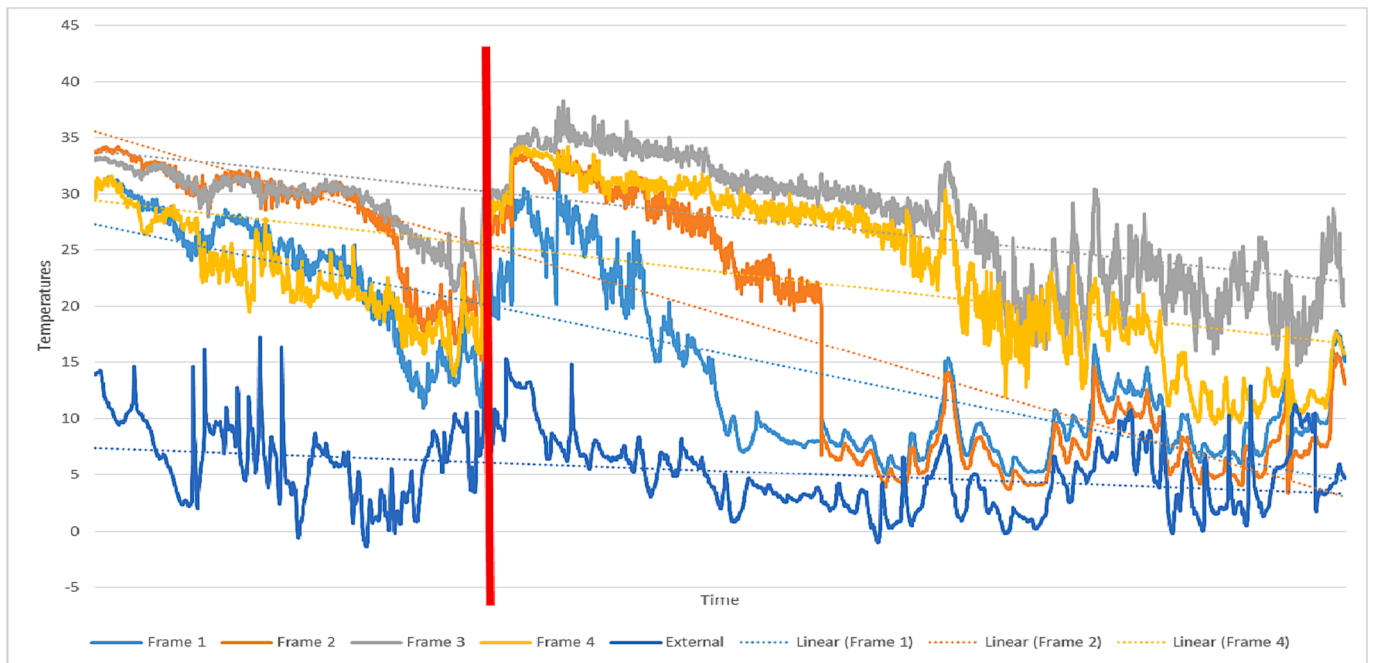

Fig. 4. Trend of internal temperatures.

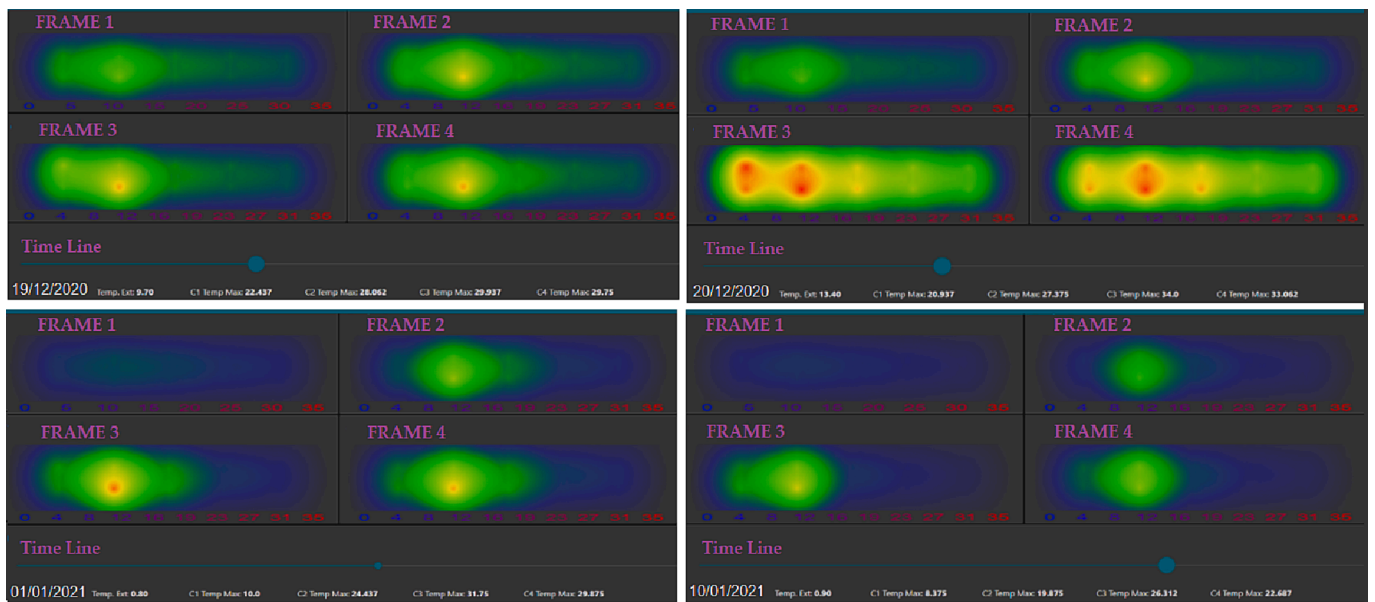

Fig. 5. Bee cluster evolution on 19/12, 20/12, 01/01 and 10/01.

Table 1  
System cost.

Hardware	Quantity	Per unit	Costs	Software	Quantity	Per unit	Costs
Load cells + HX711	4	\$6.25	\$25.00	Python	1	\$0.00	\$0.00
Raspberry Pi	1	\$58.50	\$58.50	Raspbian (RPI OS)	1	\$0.00	\$0.00
Sensor DHT 22	1	\$6.40	\$6.40	Ubuntu	1	\$0.00	\$0.00
Breadboard	1	\$3.33	\$3.33	Node-red	1	\$0.00	\$0.00
ESP32	1	\$6.72	\$6.72				
DS18B20	40	\$1.25	\$49.95	<b>Total Software</b>			<b>\$0.00</b>
Others (wires...)	1	-	-				
<b>Total Hardware</b>			<b>\$149.90</b>				

Oxalic acid is often applied in late fall or over the winter period when there are very few *varroa* under capped brood. We opted for the dribble approach which could have potentially triggered a new state of out-of-season brood rearing during a time when the bees were preparing for the winter. This is shown by the recorded gradual decrease in global temperatures and the sudden noteworthy increase just after the treatment. In view of these data, we think that the winter treatment caused an overexertion, which resulted in higher mortality. In our case, the above-mentioned reaction happened on 20/12 when the temperatures rose from 29 °C to 34 °C after the treatment was given. The bees were able to maintain maximum temperatures around 30 °C, except at the end, on 10/01, which dropped to 26°. Fig. 5 depicts the evolution during the 21 days.

Although our low-cost system that uses open software technologies as MQTT and Node-RED in an open hardware platform which is royalty-free, there are important aspects to be considered for a successful implementation. Hives are often located in remote places with difficult access. The idea is that our system is installed in one or two pilot hives as opposed to an entire apiary. Table 1 shows the direct costs estimation of the system, i.e., those associated with the hardware and software. This cost would be only about \$150 per hive. Obviously, the indirect costs associated with the installation, power consumption, etc. must be added which are difficult to estimate and must be studied for each installation.

## 5. Conclusion

The described system has been able to successfully monitor the behavior of the bees during the winter season, when the hive cannot be opened, and its interior cannot be inspected. This is achieved thanks to our monitoring technique based on the construction of a complete real-time heatmap of the hive that allows to understand how the bees act inside the hive when influenced by environmental conditions helping the beekeeper to make decisions or apply possible treatments. Using our system, we have monitored the reaction of the hive during a winter *varroa* treatment.

The authors declare that they have changed and corrected the original text of the manuscript following the indications and suggestions indicated by the reviewers.

## Declaration of Competing Interest

The authors declare that they have no known competing financial interests or personal relationships that could have appeared to influence the work reported in this paper.

## Data availability

Data will be made available on request.

## References

- Cecchi, S., et al., 2019. OP Conf. Ser.: Earth Environ. Sci. 275 012016 <https://doi.org/10.1088/1755-1315/275/1/012016>.
- COLOSS. (2022, 11 02). Retrieved from <https://coloss.org>.
- Debauche, O., Moulat, M.E., Mahmoudi, S., Boukraa, S., Manneback, P., Lebeau, F., 2018. Web Monitoring of Bee Health for Researchers and Beekeepers Based on the Internet of Things. Proc. Comput. Sci. 130, 991–998. <https://doi.org/10.1016/j.procs.2018.04.103>.
- Doke, M. A., Frazier, M., & M., G. C. (2015). Overwintering honey bees: biology and management. *Current Opinion in Insect Science* 10, 185–193. doi:10.1016/j.cois.2015.05.014.
- Egils, S., Almars, B., 2013. Temperature changes above the upper hive body reveal the annual development periods of honey bee colonies. Comput. Electron. Agric. 90, 1–6. <https://doi.org/10.1016/j.compag.2012.10.003>.
- Esch, L.V., Kok, J.-L.-D., Janssen, L., Buelens, B., Smet, L.D., Graaf, D.C., Engelen, G., 2020. Multivariate Landscape Analysis of Honey Bee Winter Mortality in Wallonia, Belgium. *Environ. Model Assess* 25 (3), 441–452. <https://doi.org/10.1007/s10666-019-09682-w>.
- The European Parliament. (2019, 12 3). *What's behind the decline in bees and other pollinators? (infographic)*. Retrieved 10 21, 2021, from <https://www.europarl.europa.eu/news/en/headlines/society/20191129STO67758/what-s-behind-the-decline-in-bees-and-other-pollinators-infographic>.
- Sumpter, D., Broomhead, D.S., 2000. Shape and Dynamics of Thermoregulating Honey Bee Clusters. *J. Theor. Biol.* 204 (1), 1–14. <https://doi.org/10.1006/jtbi.1999.106>.
- Tashakkori, R., Hamza, A., Crawford, M., 2021. Beemon: An IoT-based beehive monitoring system. Comput. Electron. Agric. 190 (3) <https://doi.org/10.1016/j.compag.2021.106427>.
- van der Zee, R., Gray, A., Pisa, L., de Rijk, T., Nieh, J.C., 2015. An observational study of honey bee colony winter losses and their association with *Varroa* destructor, neonicotinoids and other risk factors. *PLoS One* 10 (7), e0131611. <https://doi.org/10.1371/journal.pone.0131611>.
- Zgank, A., 2020. Bee Swarm Activity Acoustic Classification for an IoT-Based Farm Service. *Sensor* 20 (1), 21. <https://doi.org/10.3390/s20010021>.